



Navion Service Letter No. 89
September 15, 2010

Subject: Suggested Nondestructive Inspection procedures for Landing Gear.

Contact: Sierra Hotel Aero, Inc. 1690 Aeronca Ln, So St Paul, MN 55075
Phone 651.306.1456 fax 612.677.3171 email: engineering@navion.com

Effectivity: Serial Number NAV-4-002 and Subs.

Purpose: A guide to inspecting landing gear components for the presence of corrosion and/or cracks, during gear maintenance and/or teardown due to landing incidents, to help reduce the possibility of failure of landing gear parts while in service.

Description: The landing gear should be removed, inspected and reinstalled as follows:

SHA Inc. recommends using an approved propeller, engine overhaul facility or other qualified NDI personnel/facility to perform nondestructive testing.

Jacking

- a) Disconnect Aircraft Battery.
- b) Jack aircraft per Navion Service Manual Section 5.4.

Nose Landing Gear

- a) Remove and disassemble Nose Gear Assembly per Navion Service Manual Section 13.3
- b) Strip paint on nose gear parts with paint stripper and/or media blasting.
- c) Visually inspect all nose gear parts for wear, corrosion and cracks.
- d) Florescent penetrant inspect nose gear fork part number 145-34117 and Shock strut collar part number 145-34143 or -3 by qualified NDI personnel. Extra attention on bend radius, bolt pattern and around axle attachment. (Ref. fig 1, fig 2, fig 3 and fig 4.)
- e) Magnetic particle inspect nose gear casting assembly part number 145-34103 or -30 by qualified NDI personnel. Extra attention on cross piece trunnion attachment and collar at drag link attachment. (Ref. fig 5)
- f) If cracking or damage is noted contact Sierra Hotel Aero, Inc. for technical assistance. 651.306.1456
- g) Replace all non serviceable parts per Navion Parts Manual Chapter 24.
- h) Re-apply protective coatings; use conversion coating on aluminum parts (Alodine 1201 or equivalent.)
- i) Reassemble and reinstalled Nose Gear Assembly per Navion Service Manual Section 13.3.

Main Landing Gear

- a) Remove and disassemble left and right Main Landing Gear per Navion Service Manual Section 13.2.

- b) Strip paint on left and right main landing gear part with paint stripper and/or media blasting. (Ref. Note 1)
- c) Visually inspect all main landing gear parts for wear, corrosion and cracks.
- d) Florescent penetrant inspect main landing gear oleo axle attachment fitting part number 143-33113-9 and -10 by qualified NDI personnel. Extra attention on fitting/ oleo struts joint. (Ref fig 9)
- e) Magnetic particle inspect main landing gear shock strut outer cylinder assembly part number 145-33903-1 or -101 and -2 or -102 by qualified NDI personnel. Extra attention on trunnion/ strut joint and collar and drag link attachment. (Ref fig 6, fig 7 and fig 8)
- f) If damage is found in specified areas reference SRM Fig. 5-2 and/or Fig. 5-3 and/or contact Sierra Hotel Aero, Inc for technical assistance.
- g) Replace all non serviceable parts with new parts per Navion Part Manual Chapter 24.
- h) Re-apply protective coating.
- i) Reassemble and reinstalled Left and Right Main Landing Gear Assembly per Navion Service Manual Section 13.3.

Operational Checks

- a) Reconnect Aircraft battery.
- b) Cycle Landing Gear Up and Down per Navion Service Manual Chapter 13. Check for proper gear operation and evidence of hydraulic leaks.

Jacking

- a) Lower aircraft per Navion Service Manual Section 5.4
- b) Return Aircraft to service.

NOTE 1

If steel landing gear components outer strut surface have been decorative chrome plated, it can not be properly inspected and should be remove from service.



Fig.1
Nose Fork

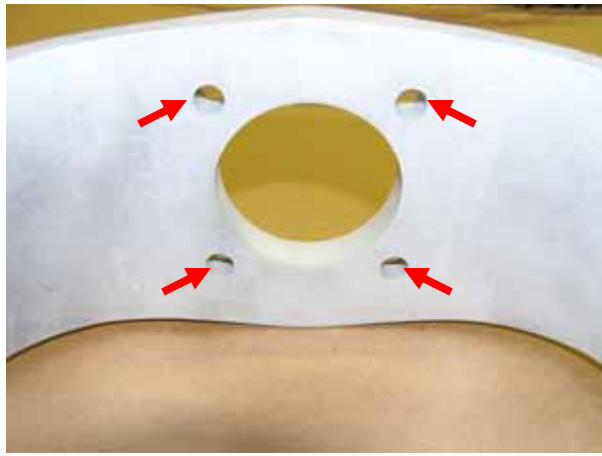

Fig.2

Closely inspect Nose fork for cracks using florescent penetrant.



Fig.3

Perform detailed visual inspection on entire Nose fork for corrosion i.e. exfoliation corrosion.



Fig. 4

Inspect for cracks with florescent penetrant and visually inspect for corrosion.



Fig. 5
Magnetic particle inspect for cracks and separation.

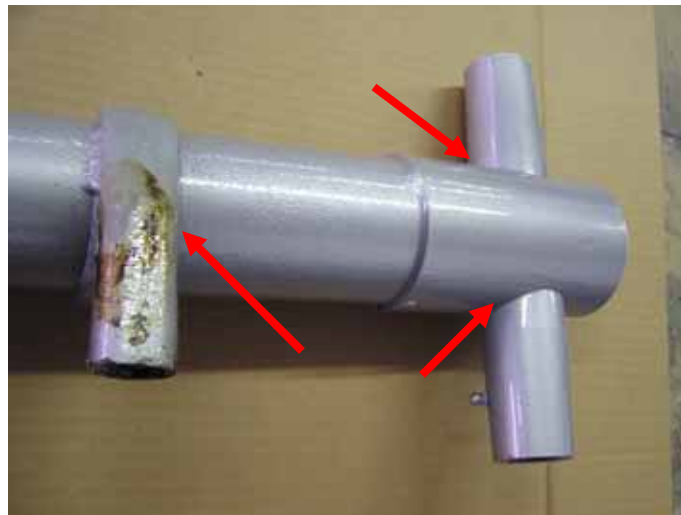

Fig. 6
Magnetic particle inspect for cracks and separation.



Fig. 7
Magnetic particle inspect for cracks and separation.

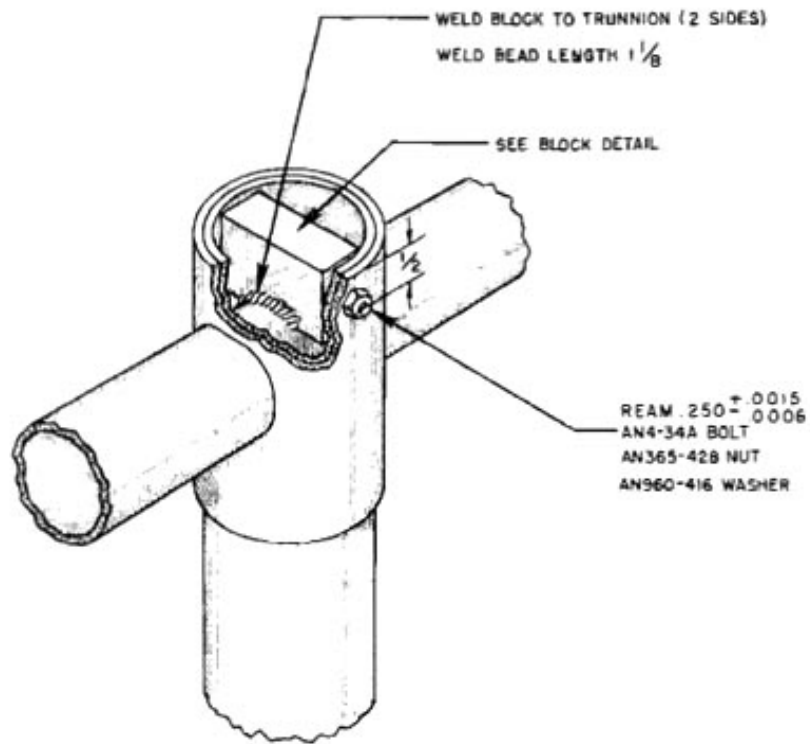

Fig. 8

Approved repair if cracks or separation are found around trunnion/ shock strut joint.
Reference: Navion SRM

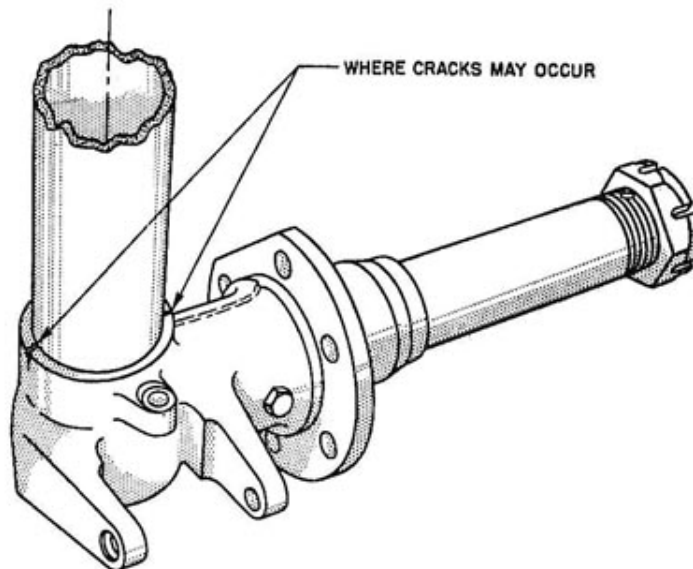

Fig. 9

Florescent penetrant inspect for cracks. If cracks are found,
contact Sierra Hotel Aero, Inc. (651.306.1456 or engineering@navion.com)